



Quick Installation Guide

X3-Hybrid 5.0KW-15.0KW

II

Tool Preparation

I

Packing List

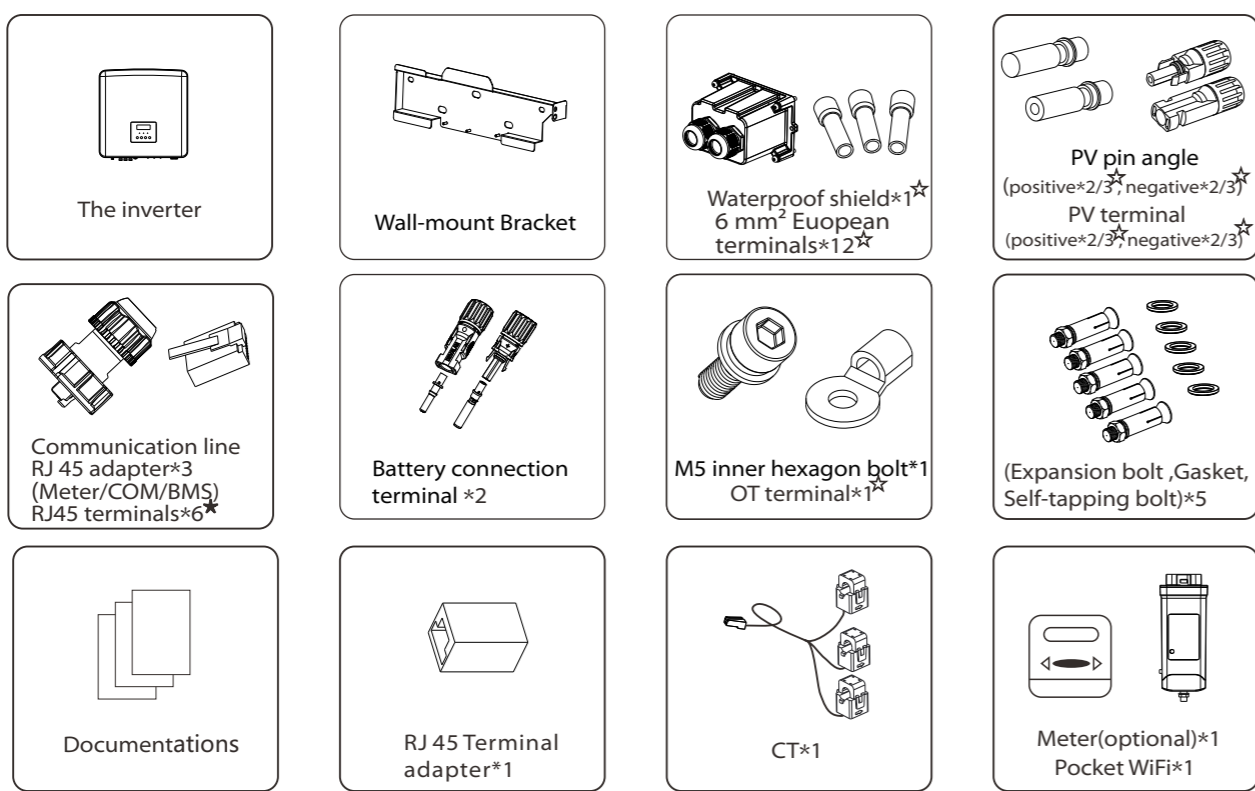

Note: * attachments are not included in the M series inverter attachment package and will be included in the X3-Matebox.
 * the inverter in Australia needs to be connected to DRM, which is 1 more communication line adapter than that in other countries.
 The number of "D" and "E" are different for different power sections. For 5-6kW inverters, the number of positive and negative PV terminal and PV pin angle is 2, 2, 2 and 2 respectively. For 8-15kW inverters, the number of positive and negative PV terminal and PV pin angle is 3, 3, 3 and 3 respectively.

III

Mounting Steps

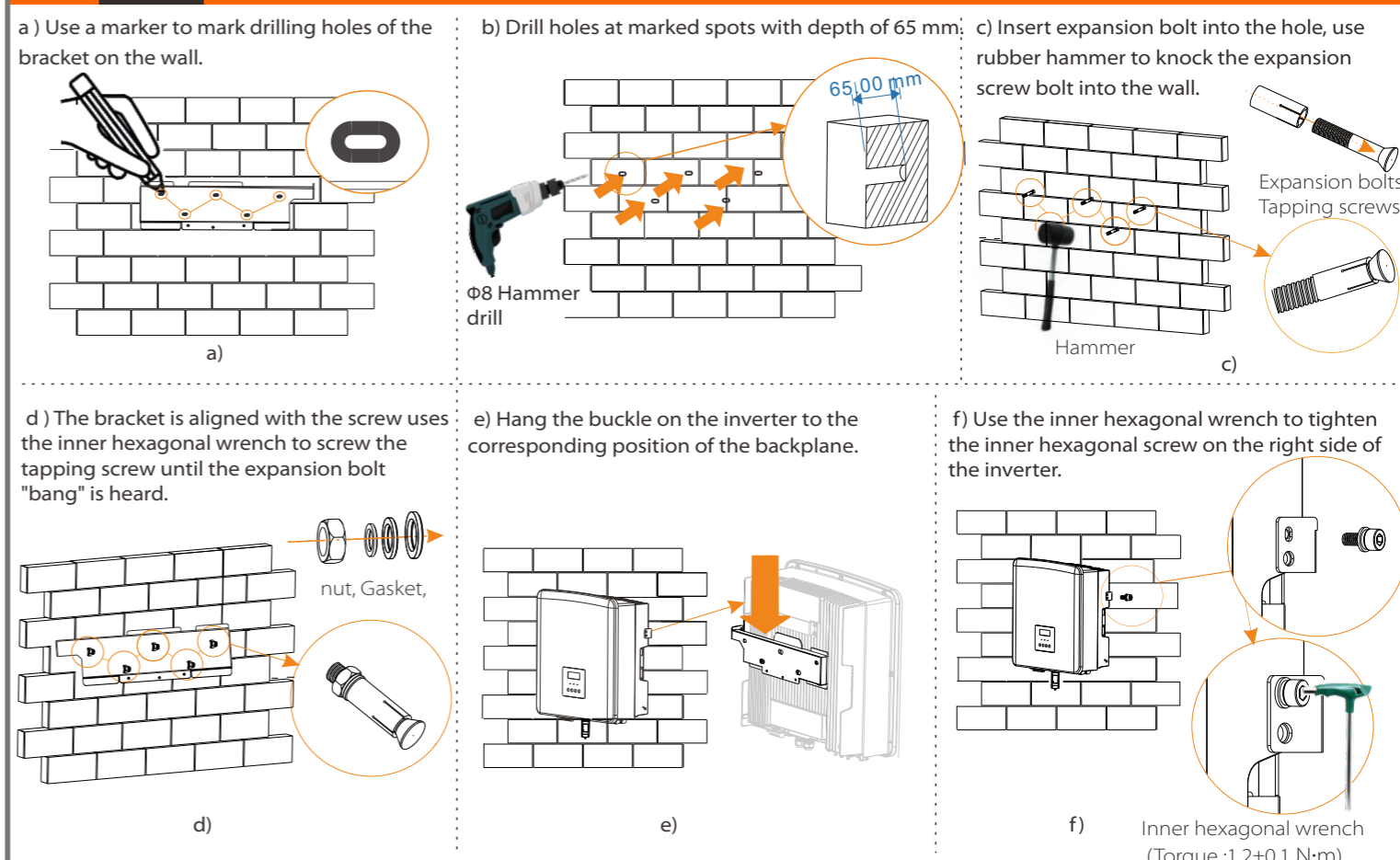

IV

PV Connection

*The PV port wiring of the M series inverter has been completed. For specific installation details, please refer to the X3-Matebox Quick Installation Guide, the D series needs to be wired according to the following steps.

Step 1. Turn off the DC switch, connect the PV module, prepare a 4 mm² PV cable, and find the PV (+) terminal and PV (-) terminal in the package.

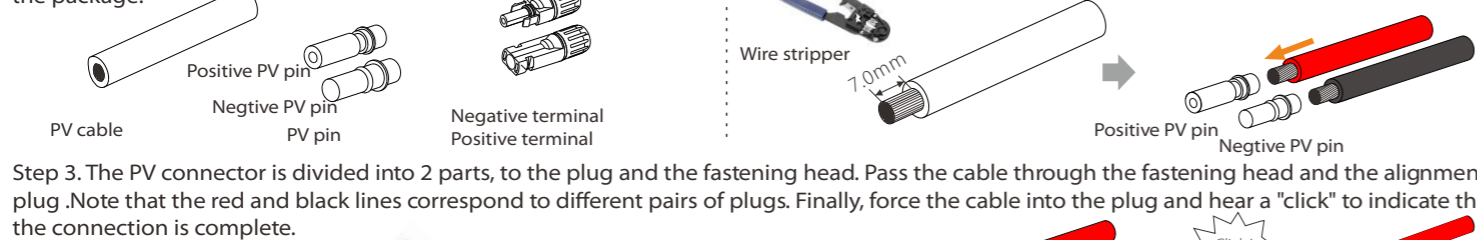

Step 3. The PV connector is divided into 2 parts, to the plug and the fastening head. Pass the cable through the fastening head and the alignment plug. Note that the red and black lines correspond to different pairs of plugs. Finally, force the cable into the plug and hear a "click" to indicate that the connection is complete.

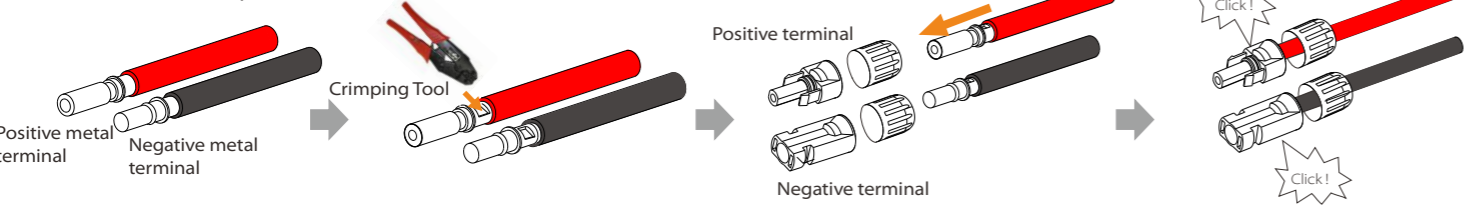

Step 4. Tighten the fastening head and insert the corresponding positive and negative (PV-/PV+) ports of the inverter.
 Note: Before inserting the PV terminal, please turn on the switch of the PV module, and use a multimeter to measure the positive and negative poles of the PV terminal port to prevent reverse connection.

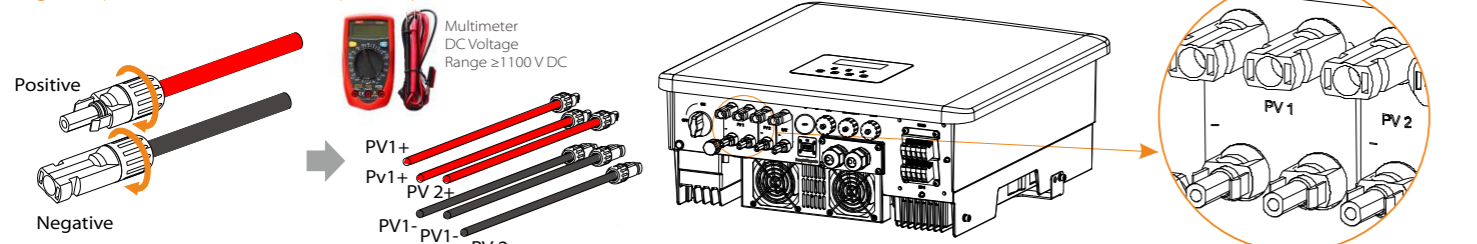

V

Grid and EPS(Off-grid) Connection

Diagram A: N line and PE line separate wiring, D series inverter; (For most countries)

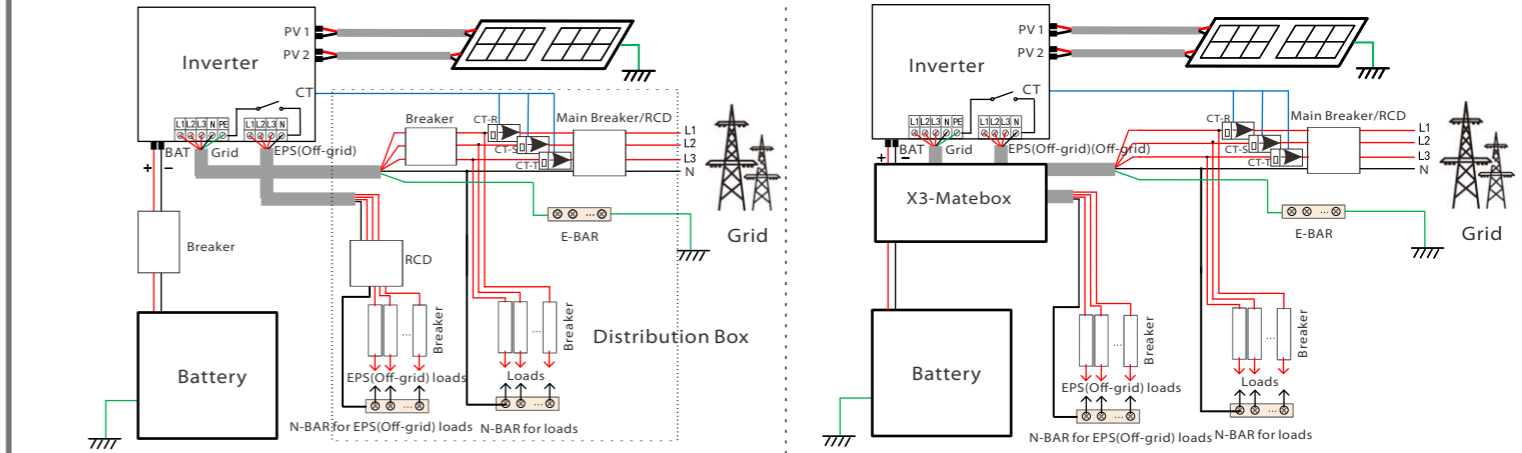

Diagram B: N line and PE line separate wiring, M series inverter; (For most countries)

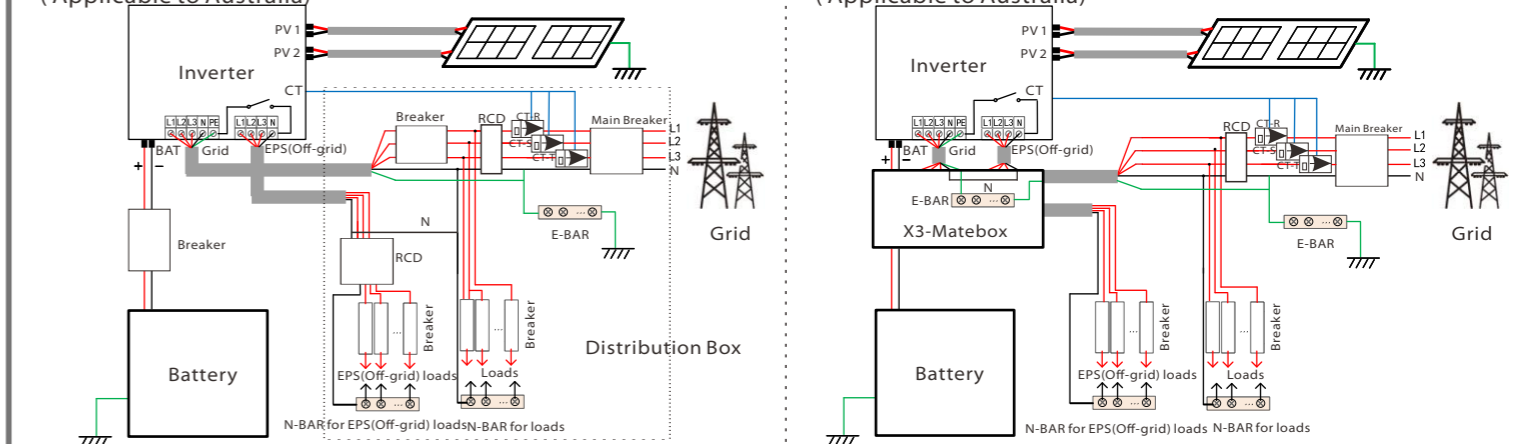

Diagram C: N line and PE line together, D series inverter; (Applicable to Australia)

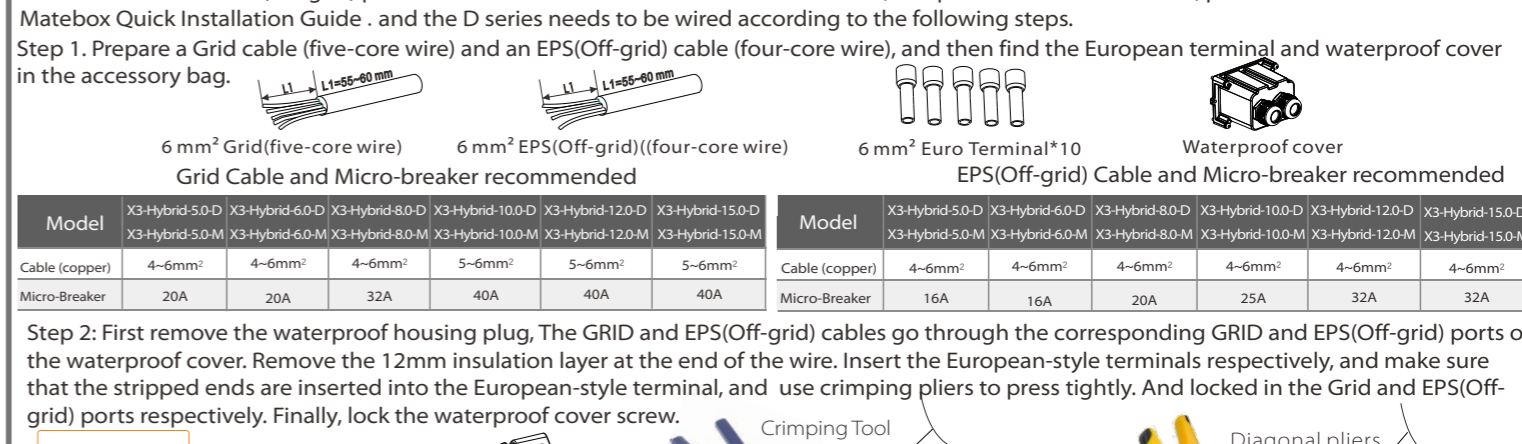
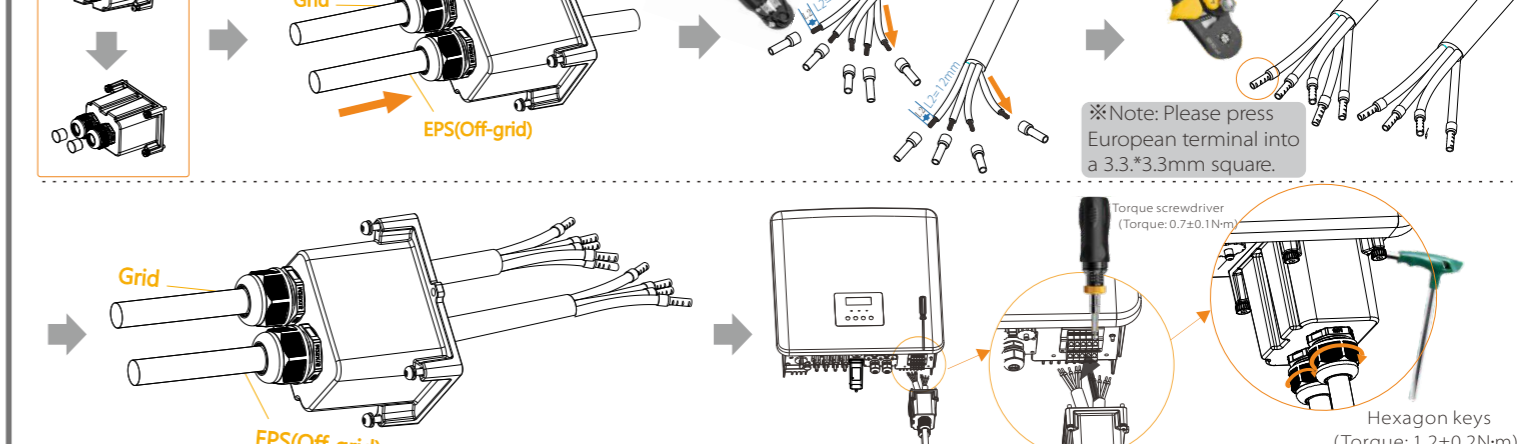

Diagram D: N line and PE line together, M series inverter; (Applicable to Australia)



Note: The RCD on the figure represents a leakage protection device with a circuit breaker function.
 * The Grid and the EPS (Off-grid) ports of the M series inverter have been connected, for specific installation details, please refer to the X3-Matebox Quick Installation Guide. and the D series needs to be wired according to the following steps.

VI

Battery Connection

Battery connection diagram:

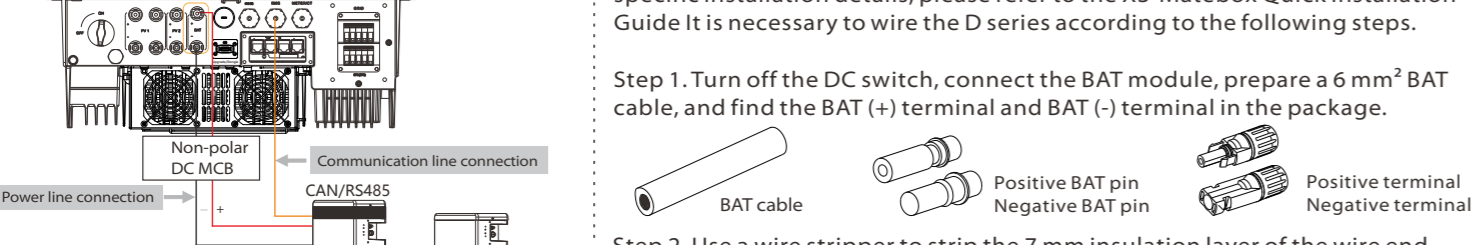

Note: When using the battery, it is recommended to use the number of battery control (1-BAT-5-B) is 1, the number of battery modules (HV11550) is 1-3, the number of battery control (MC0600) is 1, the number of battery modules (HV10230) is 2-4.

Step 1. Turn off the DC switch, connect the BAT module, prepare a 6 mm² BAT cable, and find the BAT (+) terminal and BAT (-) terminal in the package.

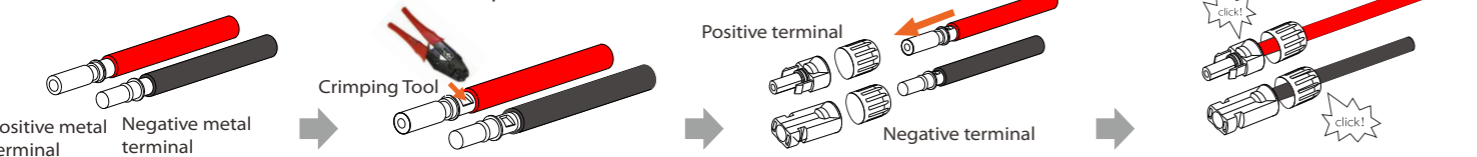

Step 2. Use a wire stripper to strip the 7 mm insulation layer of the wire end.

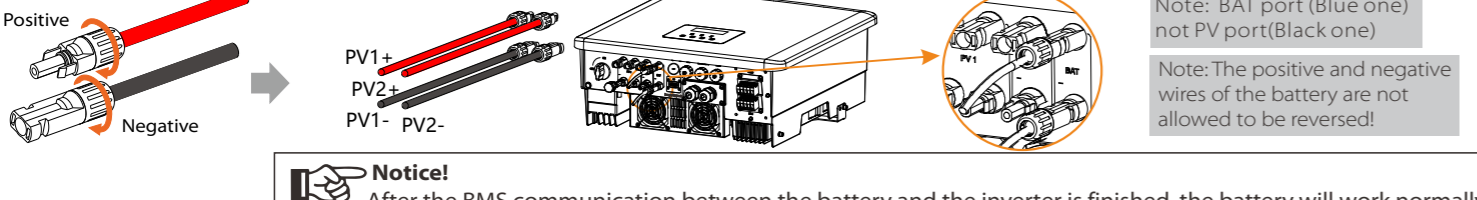

Step 3. The BAT joint is divided into 2 parts, to the plug and the fastening head. Pass the cable through the fastening head and the alignment plug. Note that the red and black lines correspond to different pairs of plugs. Finally, force the cable into the plug and hear a "click" to indicate that the connection is completed.

Step 4. Tighten the fastening head and insert into the corresponding positive and negative (BAT-/BAT+) parts of the inverter.
 Note: BAT port (Blue one) not PV port (Black one)
 Note: The positive and negative wires of the battery are not allowed to be reversed!

Notice! After the BMS communication between the battery and the inverter is finished, the battery will work normally.

VII Communication Connection (BMS/Meter/CT/COM/DRM)

Electric meter connection diagram

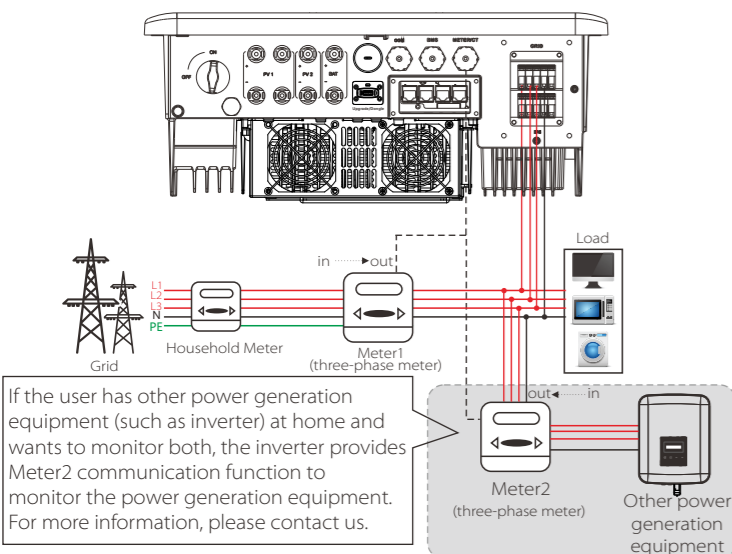

CT connection diagram

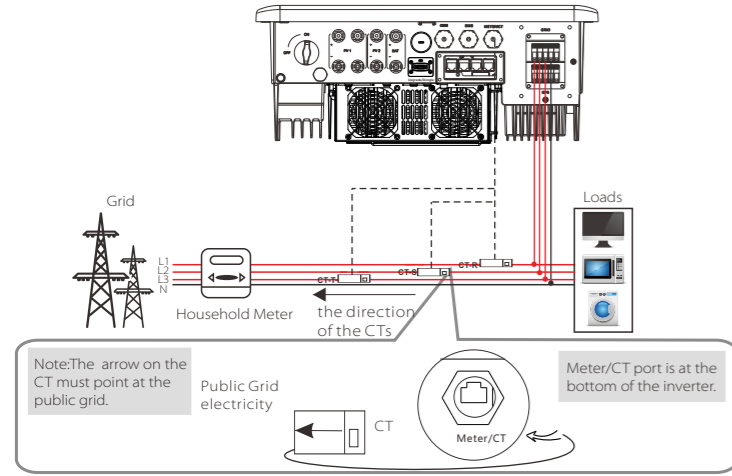

LCD settings

To select CT, you need to enter Use setting, then enter CT/Meter Setting.

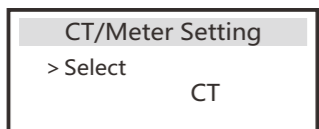

Meter/CT PIN is defined as follows:

Pin	1	2	3	4	5	6	7	8
CT-R-1	CT-S-1	CT-T-1	485A	485B	CT-F-2	CT-S-2	CT-R-2	

Note: Only one of the Meter and CT connections can be selected. Meter cable goes to pin terminal 4 and 5; CT-R cable to PIN Terminal 1 and 8; CT-S cable to PIN Terminal 2 and 7; CT-T cable is connected to terminals 3 and 6.

1) To connect the Communication line of the CT line, the lines need to be made on both sides, connecting the RJ45 terminal on one side and the Communication line Adapter on the other.

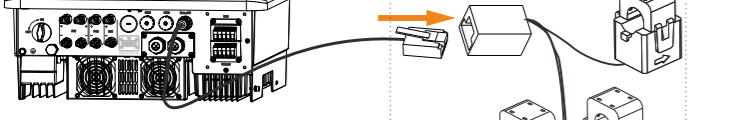
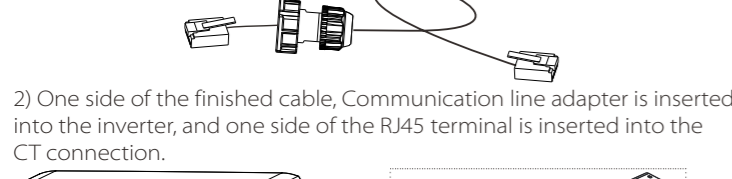

Note: When installing, pay attention to water resistance. All the connected parts of CT must be put into the distribution cabinet.

COM Communication

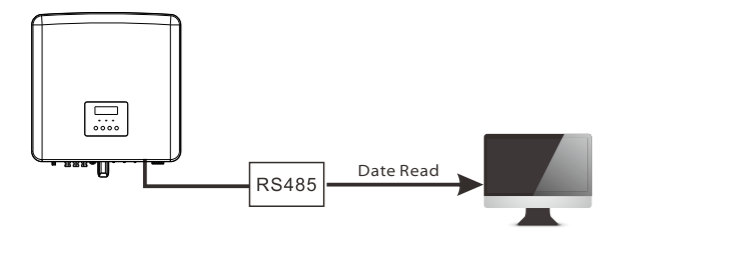

Inverter communication control external equipment:

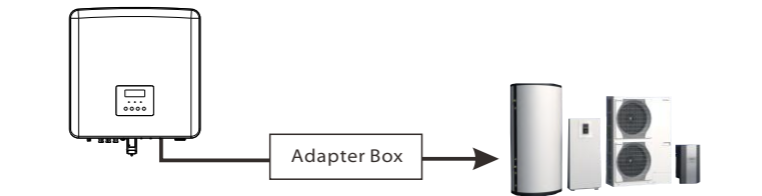

COM PIN Definition

Pin	1	2	3	4	5	6	7	8
Drcontact_Aln	Drcontact_Bln	+13V	485A	485B	GND	Drcontact_Aldsc	Drcontact_Bldsc	

Note: Customers can communicate or control the inverter and external devices through the COM interface. Professional users can use pins 4 and 5 to realize data acquisition and external control functions. The communication protocol is Modbus RTU. For details, please contact us. If the user wants to use the inverter dry contact to control external equipment (such as a heat pump), it can be used with our Adapter Box. For details, please refer to the Quick Installation Manual of the Adapter Box.

The BMS pin is defined as follows:

Pin	1	2	3	4	5	6	7	8
X	X	X	BMS_CANH	BMS_CANL	X	BMS_485A	BMS_485B	

Note: The communication port on the lithium battery must be consistent with the definition of pins 4, 5, 7, and 8 above.

The DRM pin is defined as follows:

Pin	1	2	3	4	5	6	7	8
DRM1/5	DRM2/6	DRM3/7	DRM4/8	+3.3V	DRM0	GND	GND	

Note: Currently only PIN6 (DRM0) and PIN1 (DRM1/5) are functional, other PIN functions are under development.

Communication Connection Steps

Step 1. Prepare a communication cable, and then find the communication adapter in the accessory bag.

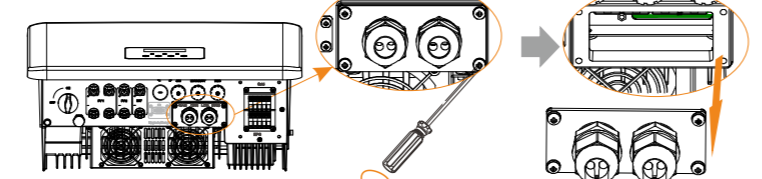

Step 3. Insert the communication cable through the communication adapter, and peel off the outer insulation layer of 15 mm.

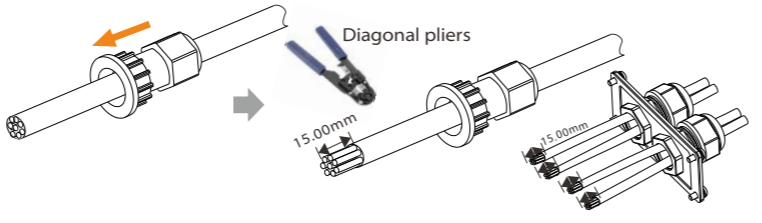

Step 4. Insert the prepared communication cables into the RJ45 terminals in sequence, and then use network cable crimping pliers to press them tightly.

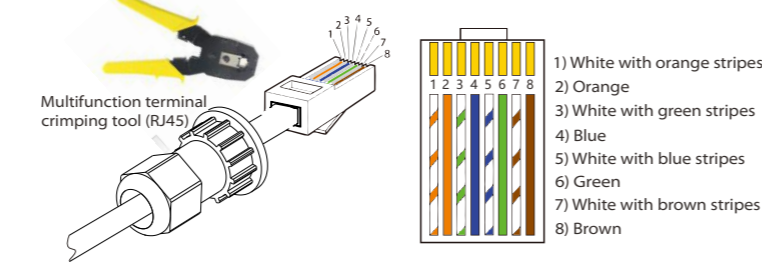

Step 5: Insert the communication line (CAN/DRM/OFF) into the corresponding port, lock the cover plate, and tighten the fastening head. Finally, the corresponding COM, METER, CT and BMS can be found to insert the corresponding ports of the inverter communication cable. And screw the communication adapter tightly.

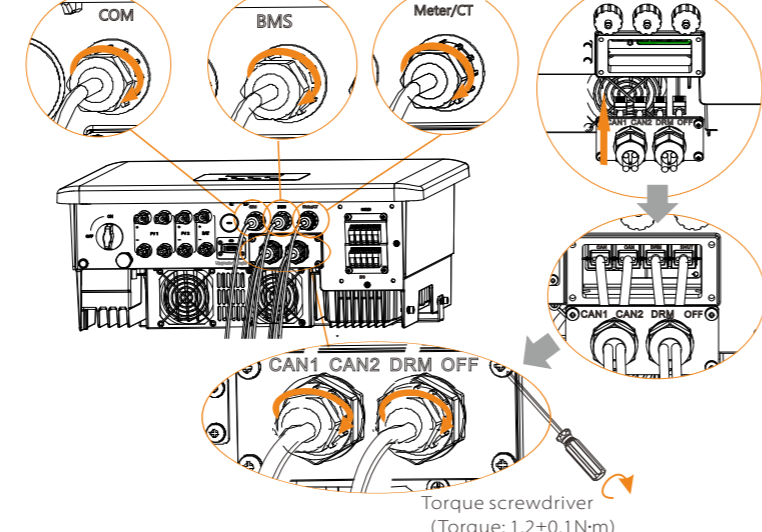

VIII Grounding Connection (mandatory)

* The ground wire port of the M series inverter has been connected, and the D series needs to be wired according to the following steps.

Step 1. Prepare a one-core cable (4 mm²), and then find the ground terminal in the accessories.

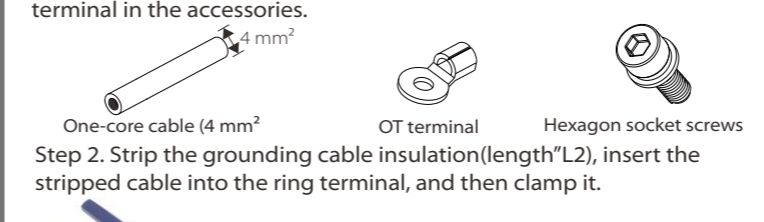

Step 2. Strip the grounding cable insulation (length "L2"), insert the stripped cable into the ring terminal, and then clamp it.

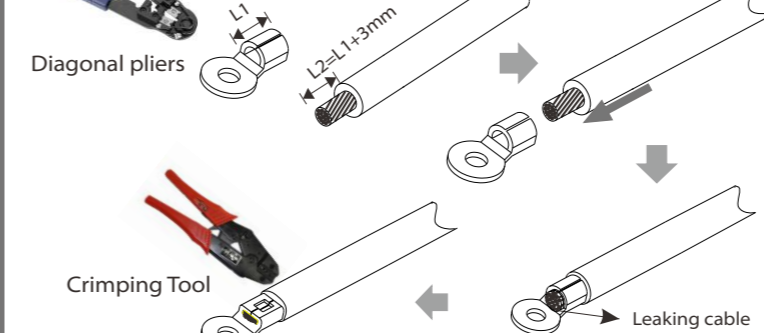

Step 4. Find the ground connection port on the inverter, and screw the ground wire with an M5 Allen key.

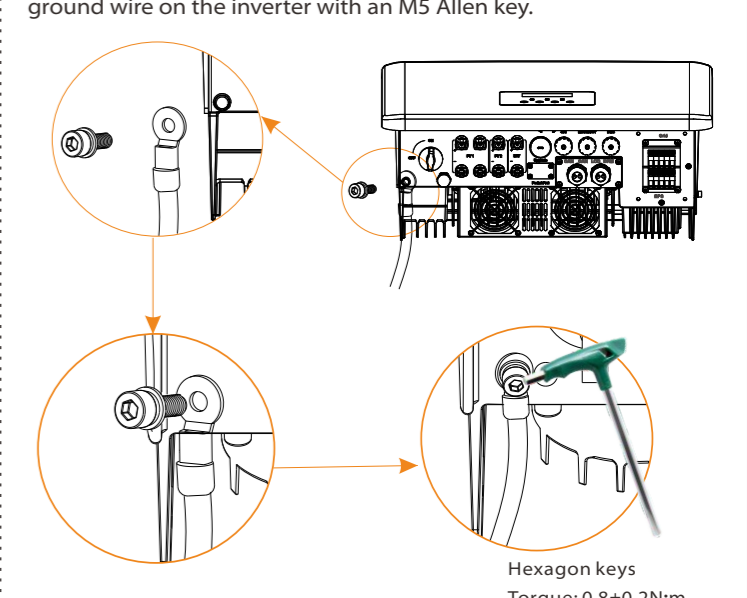

IX Monitoring Operation

DONGLE connection diagram

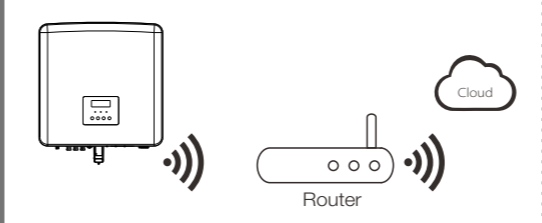

Wireless monitoring accessories connection steps:

* DONGLE port connection line of the M series inverter is on the X3-Matebox, for specific installation details, please refer to the X3-Matebox Quick Installation Guide. It is necessary to wire the D series according to the following steps.

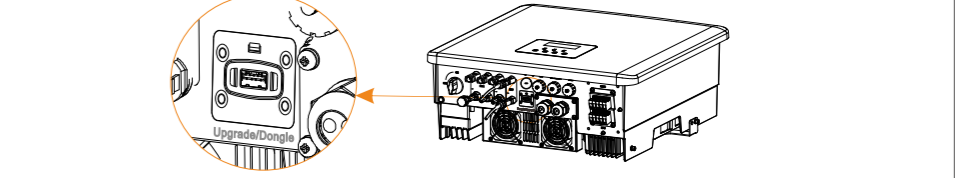

Step 2. Plug Pocket WiFi into the DONGLE port.

Please check the Pocket WiFi user manual/Pocket LAN user manual/4G user manual for more details.

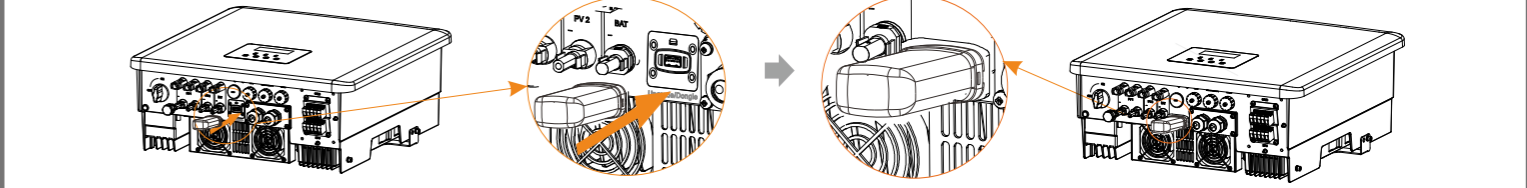

X Start Guide

1. Set date time

Date time: 2021-11-10 10:05

2. Set language

Language: English, Deutsch, Italian

3. Set the safety standard

Safety Country: > VDE0126

4. CT/Meter Setting

CT/Meter Setting: > Meter

5*. Set export control

Export Control Use Value: 10000W

6*. Set work mode

Work Mode: > Mode Select self use

7. External ATS

External ATS: Functional Control Enable/Disable

6*. Set work mode (continued)

There are 4 work modes for choice. Self use/Back Up Mode/Feed in Priority/Force Time Use. All these work modes is available for on-grid condition only.

Name	Description
Self Use	The self-use mode is suitable for areas with low feed-in subsidies and high electricity prices. ① When the power of PV is sufficient, Active Charging or Discharge time period: PV will power the battery. When the battery is fully charged, and then sell the surplus power to the grid. (The inverter will limit the output if Feed-in limit or zero feed-in is needed) (PV > Battery charge, PV → Battery → Load → Grid) ② When the power of PV is insufficient, Active Charging time period: PV will power the battery and the remaining power will be taken from the grid when PV is not enough. PV and grid power will charge the battery until it reaches the set value. And then PV will power the load and the remaining power will be taken from the grid when PV is not enough. The battery will not discharge at this time. (PV < Battery charge, PV + Grid → Battery) Active Discharge time period: PV & BAT will power the loads together. If the power is still not enough, the remaining power will be taken from the grid. (PV < Load, PV + Battery + Grid → Load) ③ Without PV power Active Charging time period: The grid supplies the loads and also can charge the battery. (PV=0, Grid → Load + Battery) Active Discharge time period: The battery will power the home loads firstly. If the battery power is not enough, the remaining power will be taken from the grid. The inverter will enter into the standby state. (PV=0, Battery+Grid → Load) Battery min SOC can be set: 10%-100%; Charge battery to min SOC can be set: 10%-100%. The Feed-in priority mode is suitable for areas with high feed-in subsidies, but has feed-in power limitation. ① When the power of PV is sufficient, Active Charging time period: PV power the battery to the set value, and then power the load, and sell the surplus power to the grid. If the local grid company limits the grid-connected power of the inverter, the excess energy continues to charge the battery. (PV > Battery, PV → Battery → Load → Grid → Battery) Active Discharge time period: The inverter will enter into the standby state. (PV=0, Battery+Grid → Load) Battery min SOC can be set: 10%-100%; Charge battery to min SOC can be set: 30%-100%. The Back-up mode is suitable for areas with frequent power outages. Same working logic with 'Self-use' mode. This mode will maintain the battery capacity at a relatively high level. (Users' setting) to ensure that the emergency loads can be used when the grid is off. Customers no need to worry about the battery capacity. Battery min SOC can be set: 30%-100%; Charge battery to min SOC can be set: 30%-100%. The EPS (Off-grid) mode is used when the power grid is off. System will provide emergency power through PV and batteries to supply power to the household loads. (Battery is necessary) ① When the power of PV is sufficient, PV will power the loads firstly, and surplus power will charge to the battery. (PV > Load, PV → Load → Battery) ② When the power of PV is insufficient, The remaining power will be taken from the battery. (PV < Load, PV + Battery → Load → Battery) ③ Without PV power The battery will power the emergency loads until the battery reached the min SOC, then the inverter will enter into the idle mode. (PV=0, Battery → Load) The battery will power the emergency loads until the battery reached the min SOC, then the inverter will enter into the idle mode. (PV=0, Battery → Load) EPS (Off-grid) SOC-min condition is adjustable within the range of 1.0%-25%.

5*. Export Control

This function allows the inverter able to control energy exported to the grid. There are user value and factory value. The factory value is default which can not be charged by user. The user value set by installer must be less than the factory value.

XI Start Inverter

Start inverter

After the inverter is checked, the inverter will take the following steps:

Applies to most countries

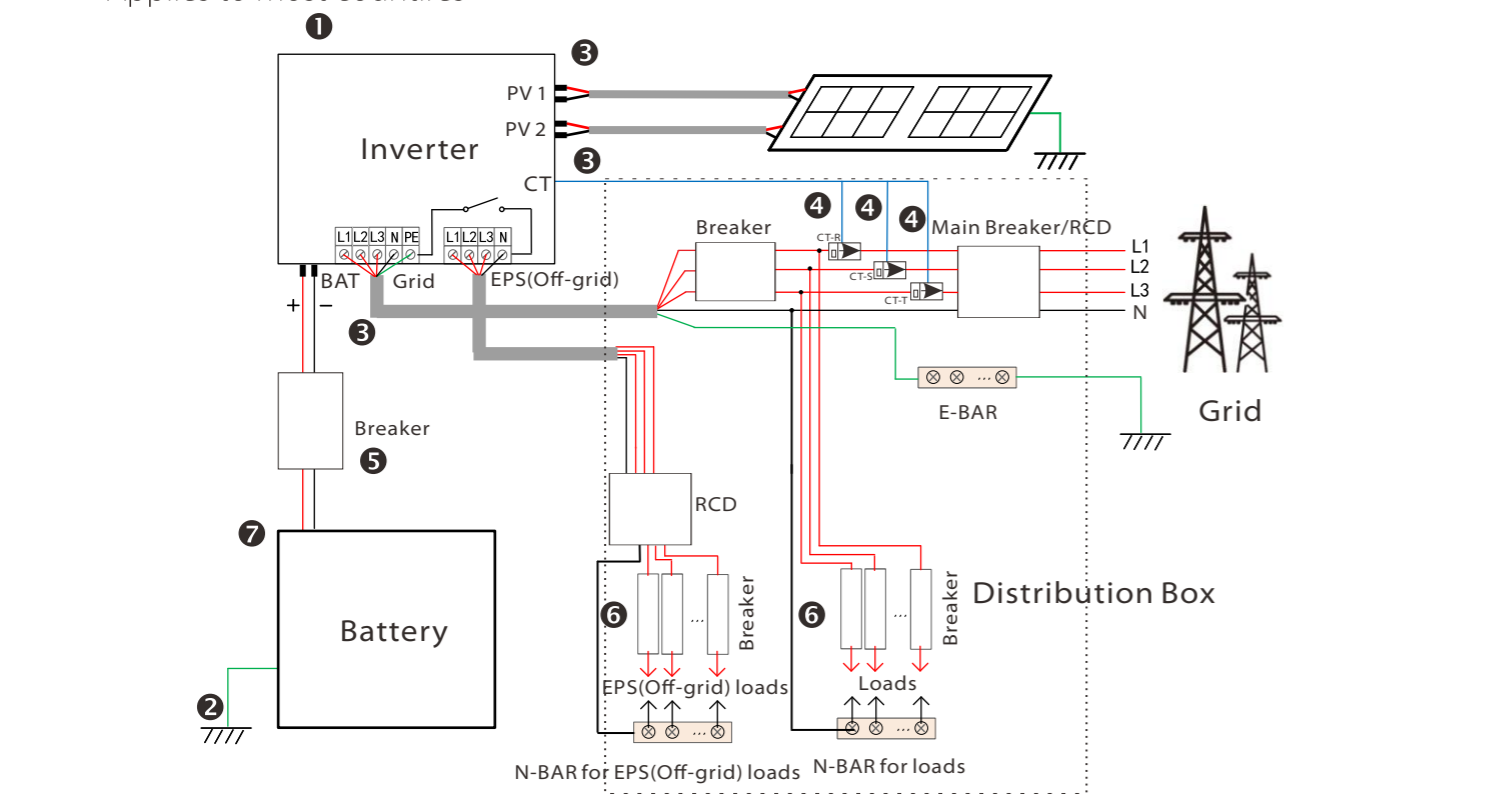

- Make sure that the inverter is fixed on the wall.
 - Ensure that all ground wires are grounded.
 - Confirm that all DC lines and AC lines are connected.
 - Make sure the CT are connected.
 - Make sure the battery is well connected.
 - Turn on the Load switch and EPS (Off-grid) switch
 - Turn on the battery switch.
- Long press Enter for 5 seconds to exit the shutdown mode. Mode is the mode when it is turned off for the first time; factory default: off mode)

Note: The RCD on the figure represents a leakage protection device with a circuit breaker function.

XII Firmware Upgrading

-In order to upgrade the firmware smoothly, if the DSP and ARM firmware needs to be upgraded, please note that ARM firmware must be upgraded first, then DSP firmware!
-Make sure that this directory is completely consistent with the above table, do not modify the firmware file name, otherwise, the inverter may not work!
-For the inverter, ensure that the PV input voltage is greater than 180V (upgrade on sunny days), please ensure that the battery SOC is greater than 20% or the battery input voltage is greater than 180V. Otherwise, it may cause serious failure during the upgrade process!
-If the ARM firmware upgrade fails or stops, please do not unplug the U disk and power off the inverter and restart it. Then repeat the upgrade steps.

Upgrade preparation

- Please check the inverter version and prepare a U disk (USB 2.0/USB3.0) and personal computer before upgrading.
- Please contact our service support through service to obtain the firmware, and store the firmware in the U disk according to the following path.
Update:
For ARM file: "update\ARM\618.00406.00_HYB_3P_ARM_V1.13_1220.usb";
For DSP file: "update\DSP\618.00405.00_HYB_3P_DSP_V1.14_1215.usb";

Upgrade steps

Step 1. Please save the "Update" firmware in your U disk first, and press the "Enter" button on the machine screen for 5 seconds to enter the shutdown mode. Then unscrew the waterproof cover, insert the U disk into the "upgrade" port at the bottom of the inverter.

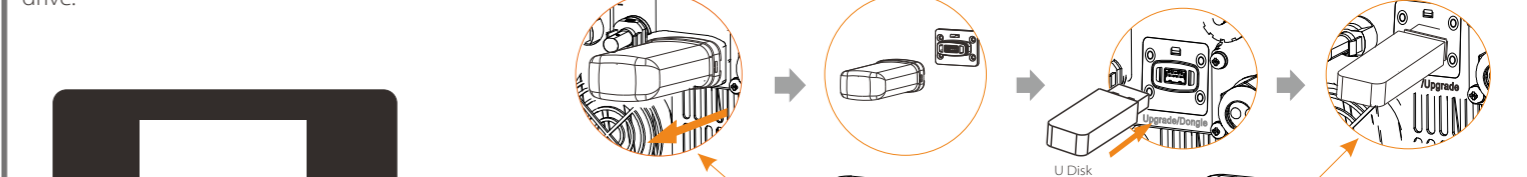

Step 2. Find the "Upgrade" port of the inverter, unplug the monitoring module (Pocket WiFi/ Pocket 4G/ Pocket LAN) by hand, and insert the USB flash drive.

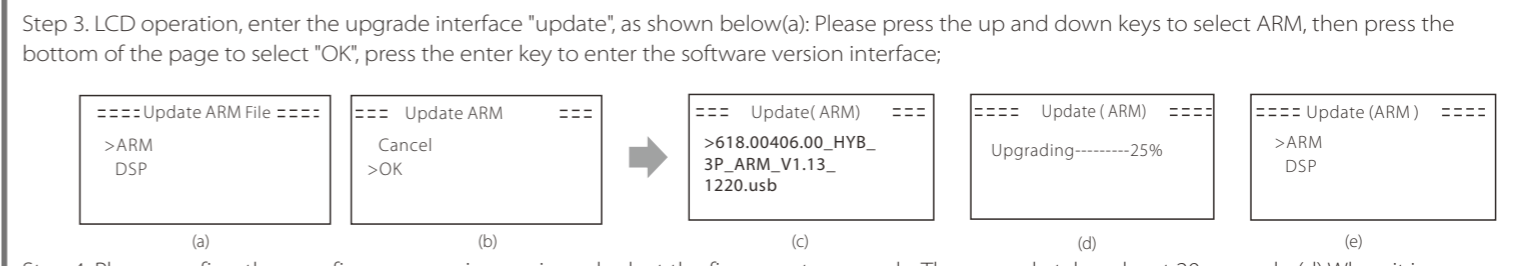

Step 3. LCD operation, enter the upgrade interface "update", as shown below (a); Please press the up and down keys to select ARM, then press the bottom of the page to select "OK", press the enter key to enter the software version interface;

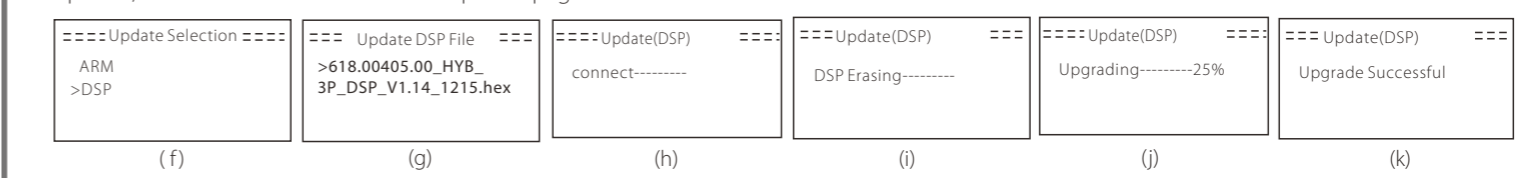

Step 4. Please confirm the new firmware version again and select the firmware to upgrade. The upgrade takes about 20 seconds. (d) When it is completed, the LCD screen returns to the "Update" page.